

Operation manual
Electronic
buttonhole machine

Texi O

 ***texi***®

I.	Important safety instruction.....	4
II.	Specification.....	5
1.	Model.....	5
2.	Specification.....	5
3.	Standard patterns of buttonholes.....	6
4.	Main parts.....	7
III.	Installation.....	8
1.	Set-up of the table.....	8
2.	Connecting the power cord.....	9
3.	Installing the sewing machine main unit.....	9
4.	Tilting the sewing machine head.....	10
5.	Connecting the safety switch connector.....	11
6.	Installing the hook oil shield plate	11
7.	Installing the operation panel.....	12
8.	Managing the cord	13
9.	Installantion of the protection cover.....	14
10.	Fixing the temporary stop switch.....	15
11.	Thread guide rod.....	16
12.	Installing the thread stand.....	16
IV.	Preparation before sewing.....	17
1.	Lubrication.....	17
2.	Inserting the needle.....	18
3.	Threading.....	19
4.	Threading the bobbin case.....	20
5.	Adjusting bobbin thread tension.....	21
6.	Installation of bobbin case.....	22
7.	Installing the knife.....	23
V.	Maintenance.....	24
1.	Adjusting the needle.....	24
2.	Adjusting the needle thread trimmer.....	25
3.	Adjusting the presser bar pressure.....	26
4.	Adjusting of the bobbin presser unit.....	27
5.	Thread tension.....	27
6.	Cleaning the filter.....	28
	TROUBLES AND CORRECTIVE MEASURES.....	29/30
	CE Delclaration of conformity.....	31

I. IMPORTANT SAFETY INSTRUCTION

SAFETY RULES

This instruction manual contains important guidelines regarding correct, safe and economical method of use of the machine. Following recommendations contained in this manual will decrease work down-time, increase machine reliability and durability, and will make work safer.

This instruction manual must always be available at the workplace. The machine can be serviced only by an employee trained in Industrial Safety, after reading this instruction manual.

The supplier is not responsible for damages caused by improper use or by usage of this product for functions other than those it has been designed for.

GENERAL SAFETY PRECAUTIONS

To minimize the risk of fire, electric shock, or injury, observe the following precautions:

- Keep the workplace clean.
- Pay attention to the machine's work environment; do not subject it to atmospheric conditions.
- Do not install the machine in rooms that are dusty, where aerosols are sprayed, or to which oxygen is supplied.
- Keep the workplace well lit.
- Be careful of danger of electric shock.
- Pay attention to clothing. Let-down hair or loose clothing can be caught by the machine's mobile elements.
- Take care not to damage the power supply cable.
- When the machine is not in use, disconnect it from the power grid.
- Take care not to turn-on the machine accidentally.
- In case of even the slightest damage, always check if the damaged part requires replacement.
- Never install on the machine attachments and accessories other than those recommended by the manufacturer and supplier.
- Do not perform machine modifications independently.
- Do not leave near the machine unattended bystanders or children.

Electric installation

Check if the supply voltage in the electric socket corresponds to the data on the machine's rating plate 1-phase voltage 230V 50Hz.

Check the correctness of electric connections in the plug and electric socket, **observing electric shock safety countermeasures.**

Do not use extension power cords.

Apply the valid electrical and Industrial Safety norms.

ATTENTION – all work related to the electrical installation must be carried out by a qualified electrician.

Before starting work

Using machine without any of the safeguarding parts (finger guard, eye guard, etc.) is dangerous to an operator.

During work, only the items necessary for sewing should be found on the machine's work table.

Before connecting the machine to the power grid, always release the pedal and the start button.

Do not use blunt or bent needles.

Do not touch any of the machine's mobile elements, such as the needle, needle bar, thread tensioner or take-up, or hook, during its operation.

Turn machine off before: replacing needle, threading, installing attachments, changing the bobbin or bobbin case.

If you notice any abnormalities in the machine's function, turn it off immediately and inform a mechanic or your superior. After finishing work, turn the machine off and remove the plug from the electric socket. In case of power grid failure, disconnect the machine from the power grid.

This machine is not a toy!

We hope that you will use this machine with pleasure for a long time.

II. SPECIFICATIONS

1. Model

Texi O Computer-controlled, high-speed, lockstitch buttonholing

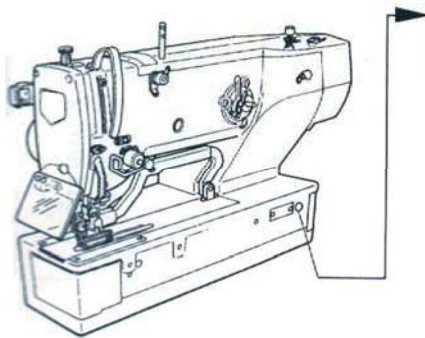







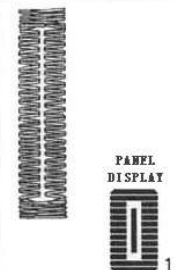
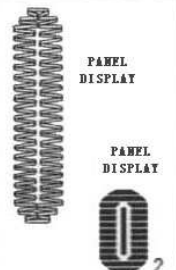
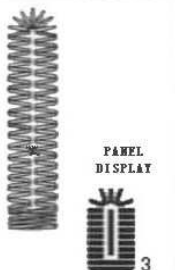
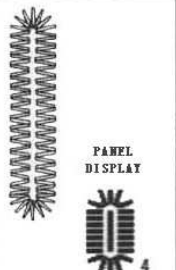
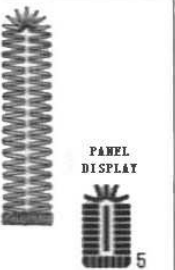
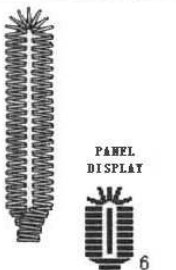

Subclass	Texi O
Major Application	Buttonholing of cloth such as men's shirts, blouses, work uniforms
Buttonholing size.	<div style="display: flex; align-items: center;">  <div style="margin-left: 10px;"> <p>Standard : 6mm</p> <p>Max. .6m</p> <p>Knife size used:</p> <p>6 . 4 ~ 31.8mm(1/4 ~ 1-1/4)</p> <p>Buttonholing sewing length:</p> <p>Standard : 120mm</p> </div> </div>

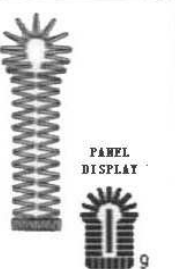
2. Specifications

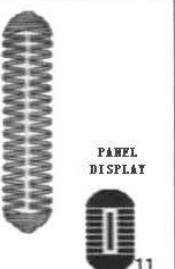
Sewing speed	Standard speed : 3600rpm(Max.: 4200rpm)
Needle	DPx5
Hook	DP type full-rotary hook
Needle rocking drive method	Drive by stepping motor
Presser lifting drive method	Drive by stepping motor
Life of presser foot	Drive by stepping motor
Lift of presser foot	6mm (Optional setting available) Max .: 17mm
Cloth cutting knife drive method	By double-acting solenoid drive
Standard sewing shape	30 kinds
Number of patterns stored in memory	99 patterns
Motor used	single phase 220V

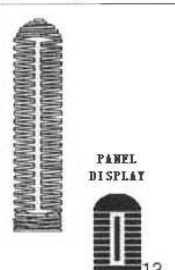
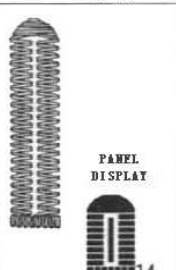
3. Standard patterns of buttonholes

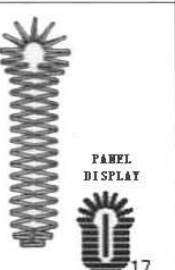
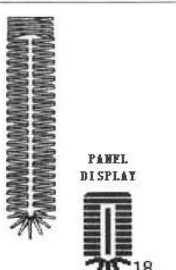
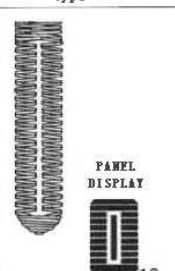
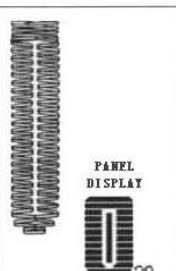
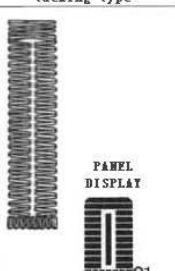
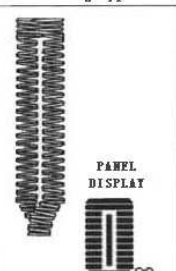
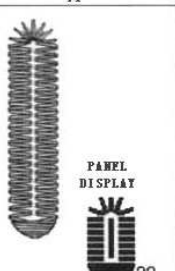
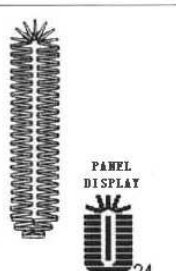
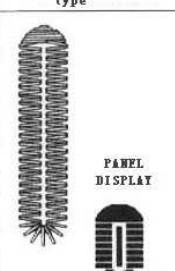
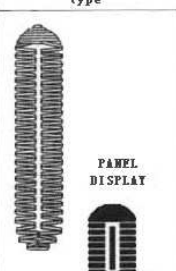
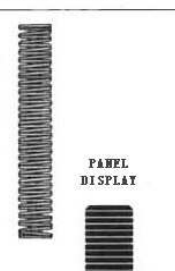
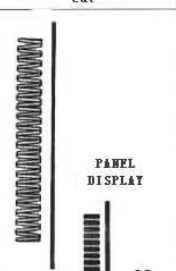
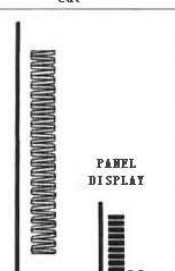
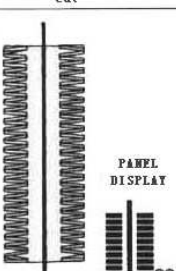
1. Square type	2. Round type	3. Radial square type	4. Radial type	5. Radial straight bar-tacking type	6. Radial taper bar-tacking type
					
7. Eyelet square type	8. Eyelet radial type	9. Eyelet straight bar-tacking type	10. Eyelet taper bar-tacking type	11. Semilunar type	12. Round square type
					
13. Semilunar square type	14. Semilunar taper bar-tacking type	15. Semilunar taper bar-tacking type	16. Eyelet semilunar type	17. Eyelet round type	18. Square radial type
					
19. Square semilunar type	20. Square round type	21. Square straight bar-tacking type	22. Square taper bar-tacking type	23. Radial semilunar type	24. Radial round type
					
25. Semilunar radial type	26. Semilunar round type	27. Bar-tacking	28. Bar-tacking, right cut	29. Bar-tacking, left cut	30. Bar-tacking, center cut
					

4 Main parts

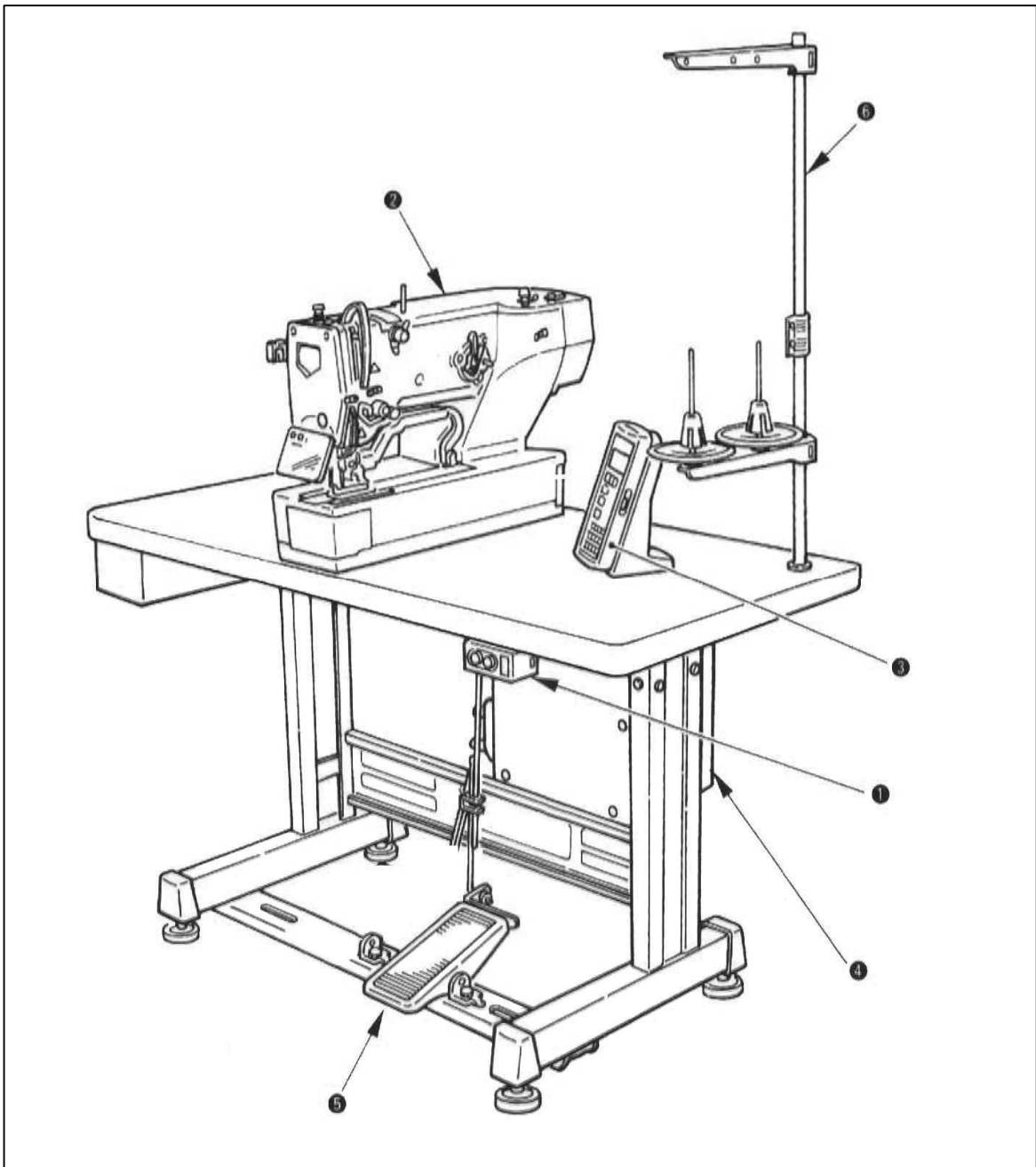

①	Power ON/OFF switch
②	Machine head (Texi O)
③	Operation panel
④	Control box
⑤	Presser lifting pedal and start pedal
⑥	Thread stand device

III. INSTALLATION

★ **WARNING:** To prevent possible accidents caused by fall of the sewing machine, perform the work by two persons or more when the machine is moved.

(1) Set-up of the table

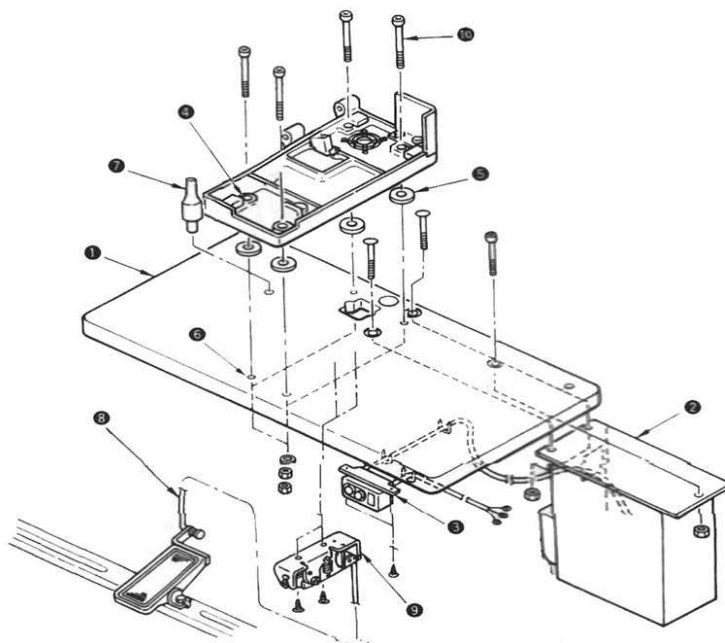

- 1) Securely install control box ② and power switch ③ on table ① .
- 2) Securely fix the respective power cables of power switch ③ .
- 3) Pass four bed base fixed screws (11) through bed base ④ .
- 4) Set rubber cushions ⑩ to holes ④ .
- 5) Fix head support bar ⑦ on table ① .
- 6) After placing the sewing machine main unit on bed base ④ , connect pedal ⑧ to pedal switch ⑨ connecting rods ⑧ which have been supplied as accessories .

▶ **CAUTION :** Adjust the positions of the pedals so that connecting rod ② do not come in contact with each other.

(2) Connecting the power cord

●Connecting single phase 220V

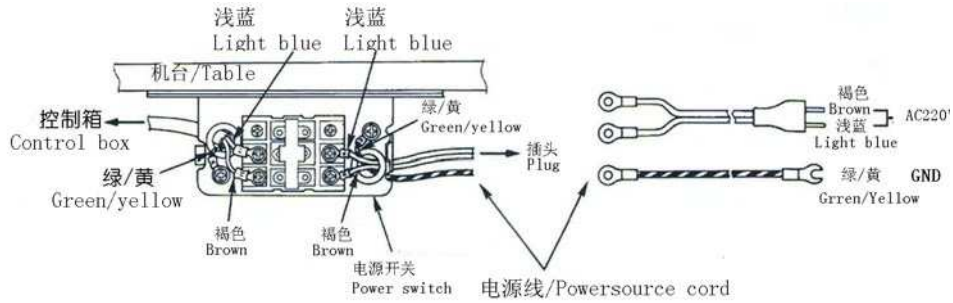

▶ CAUTION : Never use under the wrong voltage and phase.

(3) Installing the sewing machine main unit .

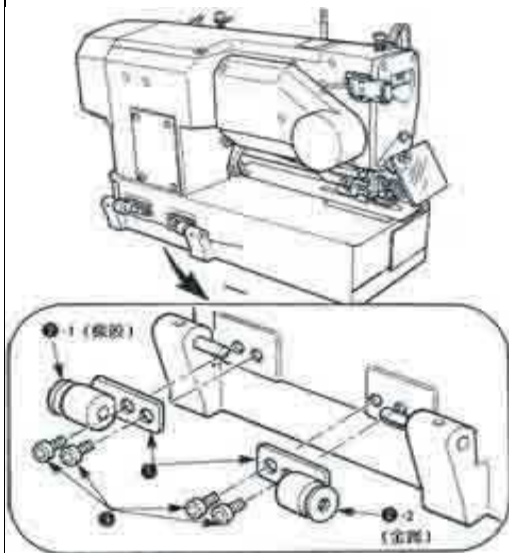

▶ CAUTION : To prevent possible accidents caused by the tail of the sewing machine, perform the work by two personal or more when the machine is moved.

CAUTION: Place hinge plates ^① and shaft bearings ^② in two places on the head base and fix the hinge plates to the machine head with setscrew ^③ in two places.

(4) Tilting the sewing machine head

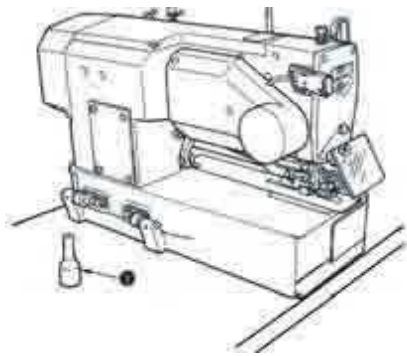

★WARNING :When tilting /raising the sewing machine head, perform the work so as not to allow your fingers to be caught in the machine, to avoid possible accidents caused by abrupt start of the machine, turn OFF the power to the machine before starting the work.

When tilting the sewing machine head, tilt quietly the sewing machine until head support bar **1** comes in.

1.Make sure that sewing machine head support bar **1** is placed on the table before tilting the sewing machine.

► **CAUTION:** 2.To protect-fall-down, be sure to tilt the sewing machine in a level place.

(5) Connecting the safety switch connector

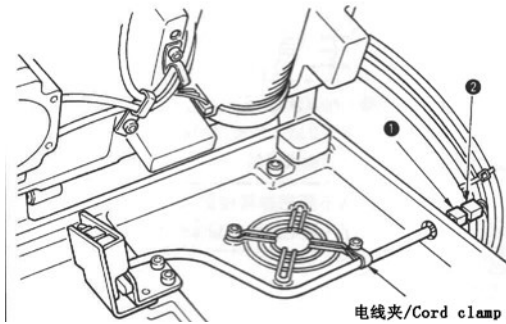

After open the machine cover, connecting safety switch connector ① with connect ② located on the PCB which is on the back of the machine.

(6) Installing the hook oil shield plate

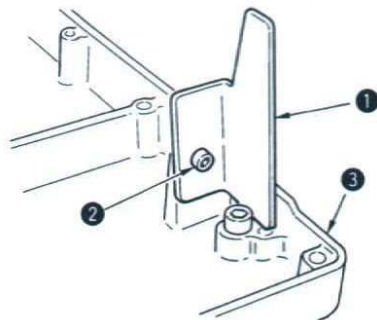

Install hook oil shield plate ② onto bed base ③ with setscrew ②.

► CAUTION : Fixes the sewing machine so that it does not come in contact with hook oil shield plate ① when raising/tilting the sewing machine.

(7) Installing the operation panel

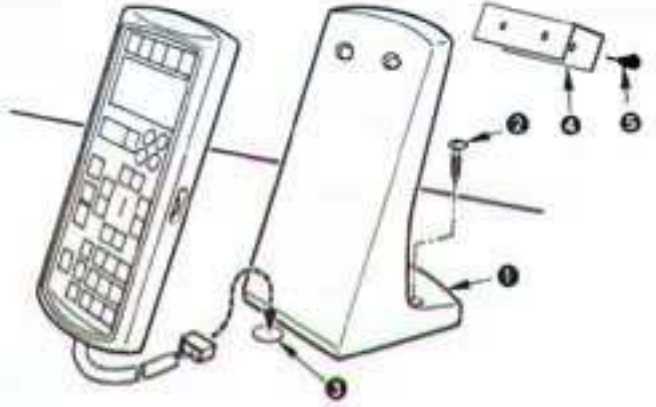

Install hook oil shield plate
① onto bed base ③ with setscrew
②

(8) Managing the cord

Slowly tilting the sewing machine, check that the cords are not forcibly pulled.

► **CAUTION** : When you tilt the sewing machine, make sure that the sewing machine head support bar  is placed on the table.

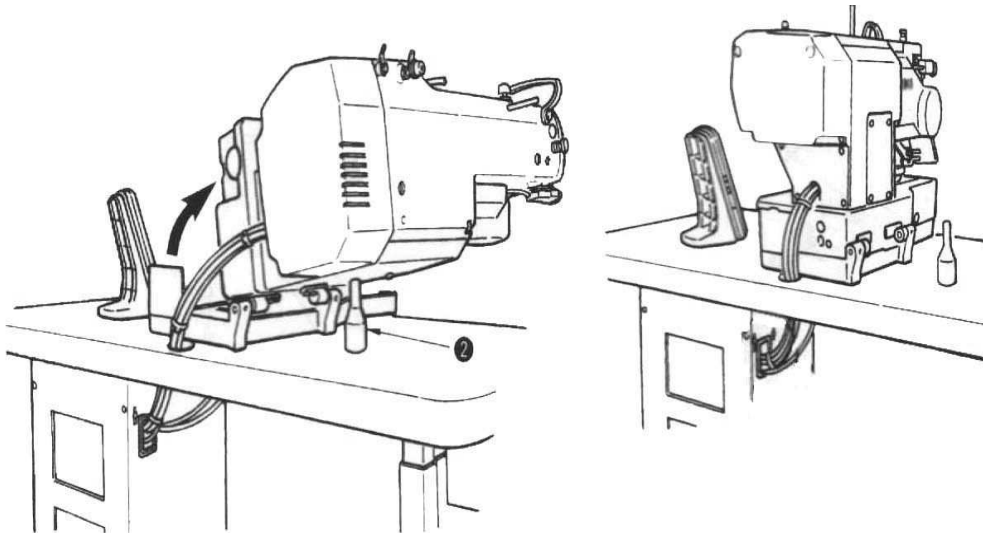

(9) Installation the protection cover

WARNING : Be sure to attach this cover to protect the eyes from the disperse of needle breakage

Be sure to install and use eye protection cover ❶ and use the sewing machine.

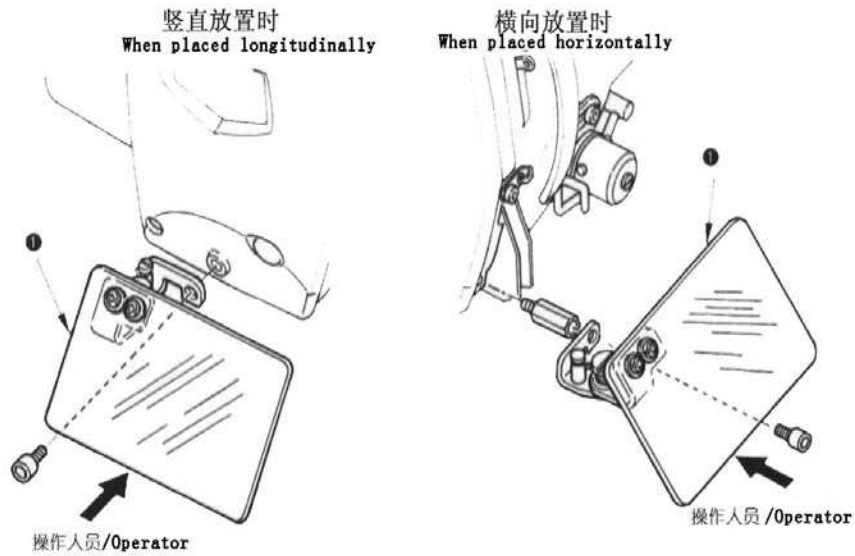

(10) Fixing the temporary stop switch

The temporary stop switch has been in the state as shown in figure A at the time of delivery. Loosen setscrew ❶ and set the switch in the state as shown in figure B, and fix it with setscrew ❶ together with setscrew ❷ supplied with the machine.

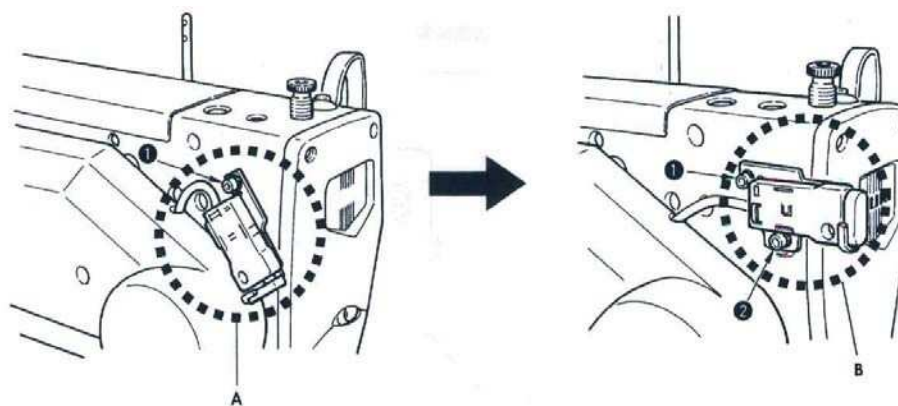

(11) Thread guide rod

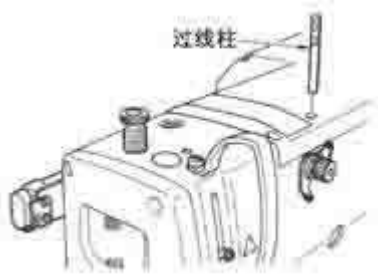

Securely fit the thread guide rod so that two side holes in the thread guide rod face the thread guide.

(12) Installing the thread stand

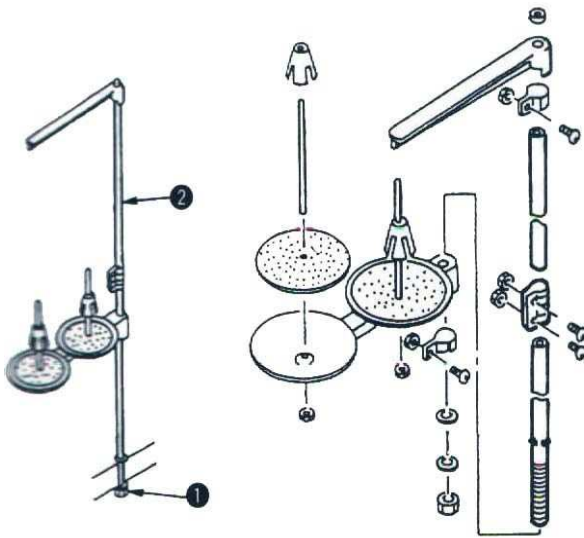

- 1) Assemble the thread stand, and set it in the hole in the top right corner of the machine table.
- 2) Tighten locknut **1** to fix the thread stand.
- 3) When ceiling wiring is possible, pass the power cord through spool rest rod **2**.

IV PREPARATION BEFORE OPERATION

1. Lubrication

WARNING : To protect against possible personal injury due to abrupt start of the machine, be sure to start the following work after tuning the power off and ascertaining that the motor is at rest.

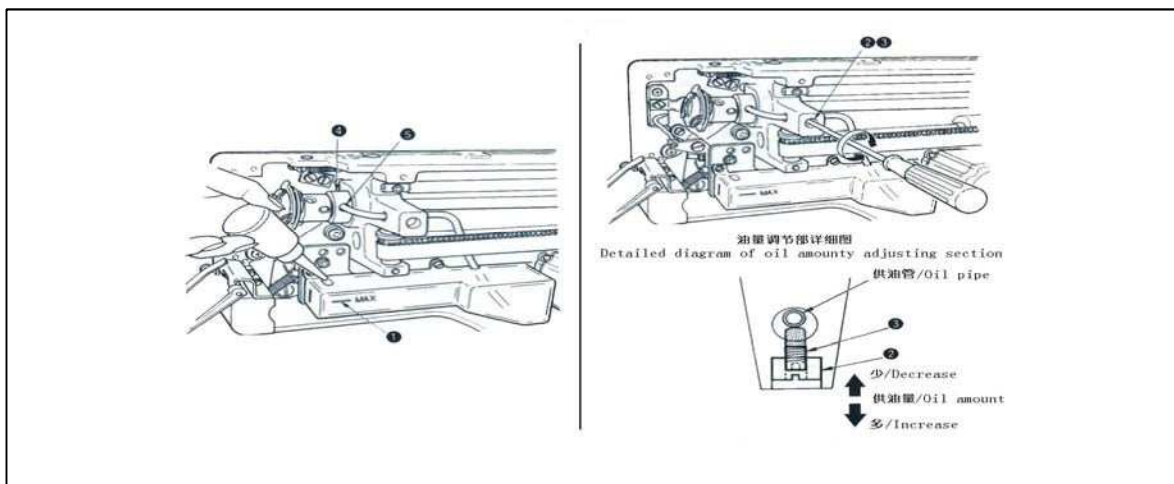

1) Lubrication oil to oiling tank.

Fill the oiling tank with Oil up to the level indicated by MAX . ① .

2) Adjusting the lubrication for the sewing hook

Adjust the amount of oil supplied to the sewing hook by loosening lock nut ② and turning of amount adjusting screw ③.

Amount of supplied oil is reduced when turning the screw ③ clockwise

Fix the screw with lock nut ② after adjusting the lubrication for the sewing hook .

When you first operate your sewing machine after set-up or after an extended period of disuse ,remove the bobbin case and apply a few drops of oil to the hook race .In addition, apply a few drops oil from oiling hook ⑤ in hook driving shaft front metal ④ to soak the inside felt in oil .

2. Inserting the needle

WARNING : To protect against possible personal injury due to abrupt start of the machine, be sure to start the following work after tuning the power off and ascertaining that the motor is at rest.

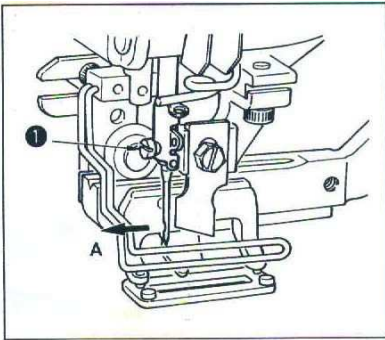

- 1) Hold needle with its recessed part facing toward the operator side A.
- 2) Insert the needle fully into the needle champing hole ,and tighten needle setscrew ①.
- 3) Use a DPx 5(#11J ~#14J).

► **CAUTION :** When attaching the needle, turn OFF the power to the motor.

3. Threading the needle-thread

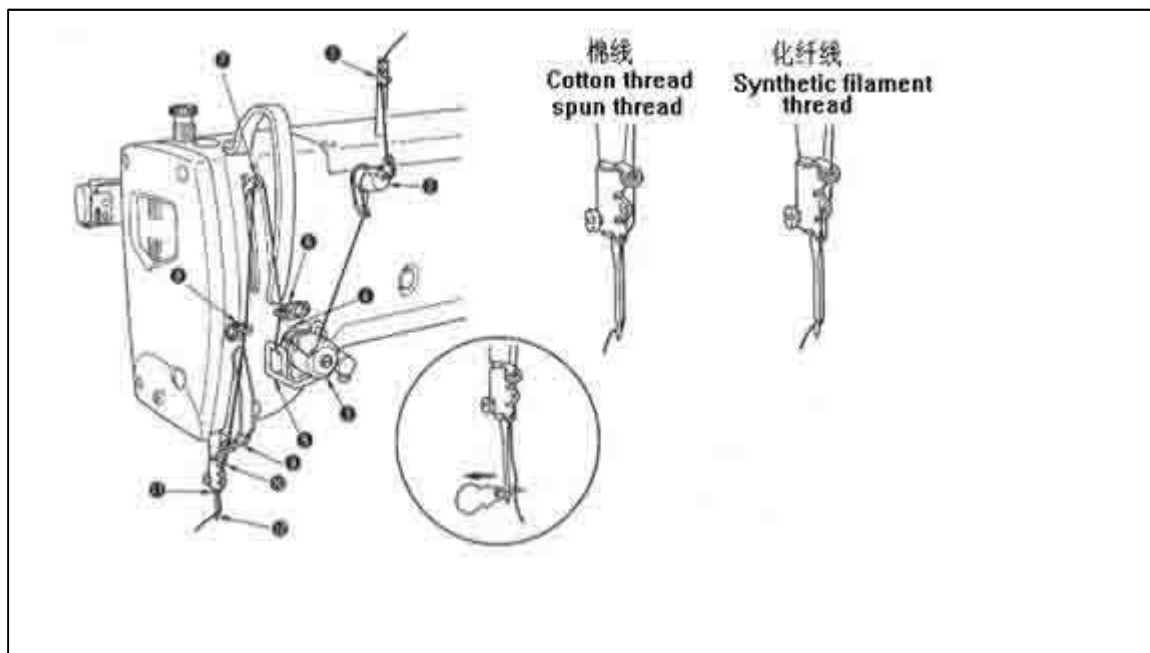

Pass the needle thread in the order ❶ to ❷ as shown in the figures.

The threading can be done easily by using the needle threader supplied with the machine.

Change the thread guide threading method according to the thread to be used.

4. Threading the bobbin case

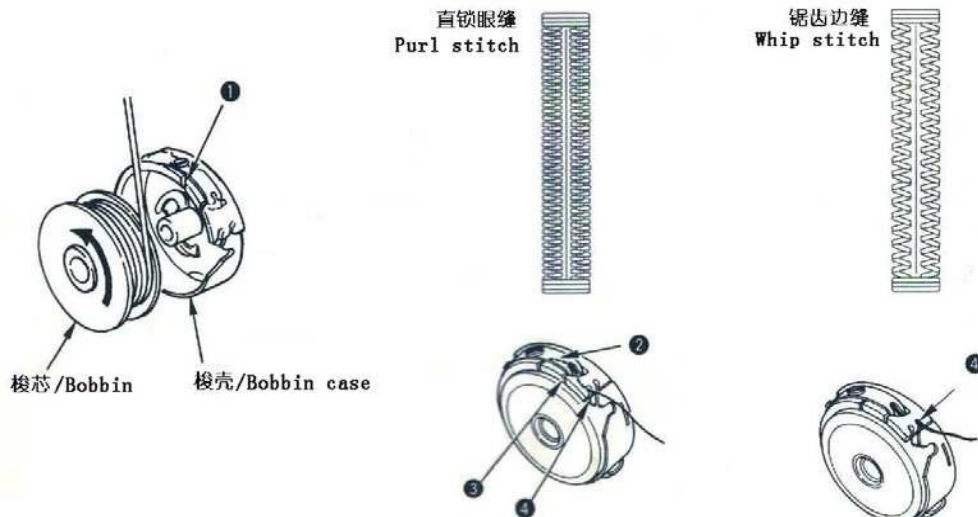

Rotating direction of bobbin and threading

- 1) Fit the bobbin so that it rotates in the direction of the arrow.
- 2) Pass the thread through thread slit ①, then through under the tension spring ②, again through thread slit ③, and pull the thread from ④.
- 3) Threading at ④ for purl stitching is different from that for whip stitching .So, be careful.

5. Adjusting the bobbin thread tension



Adjust the bobbin thread tension as given below when the bobbin thread is pulled up at the position where thread slit ❶ of bobbin case comes up .

Purl stitch	0.05~0.15N	To such an extent that bobbin case quietly comes down when holding thread end coming from bobbin case and shaking it quietly up and down.
Whip stitch	0.15~0.3N	To such an extent that bobbin case barely comes down when holding thread end coming from bobbin case and shaking it somewhat strongly.

Turning tension adjust screw ❷ clockwise will increase bobbin thread tension and turning it counterclockwise will decrease the tension.

Adjust the bobbin thread tension to lower for synthetic filament thread, and to higher for spun thread .The thread tension is higher by approximately 0.05N when the bobbin case is set to the hook since idle-prevention spring is provided.

▼CAUTION : When bobbin thread tension is adjusted, check the needle thread tension setting of the memory switch.

6. Installation of bobbin case.

WARNING: To protect against possible personal injury due to abrupt start of the machine, be sure to start the following work after

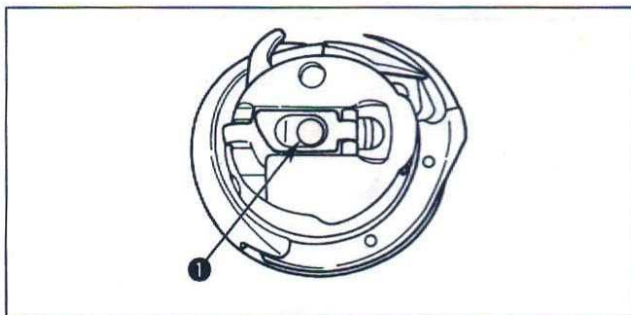

- 1) Lift up and hold bobbin case latch lever between two fingers.
- 2) Push the bobbin case into the hook so that it is supported by the hook shaft **1** and then snap in the latch lever.

Press the bobbin case until the predetermined position is reached, and it will click.

► CAUTION: If the bobbin case is out of the predetermined position, it can jump out from the hook to cause the needle thread to tangle on the hook shaft. Check to be sure that the bobbin case is properly installed in the correct position.

7. Installing the knife

WARNING : To protect against possible personal injury due to abrupt start of the machine, be sure to start the following work after turning the power of and ascertaining that the motor is at rest.

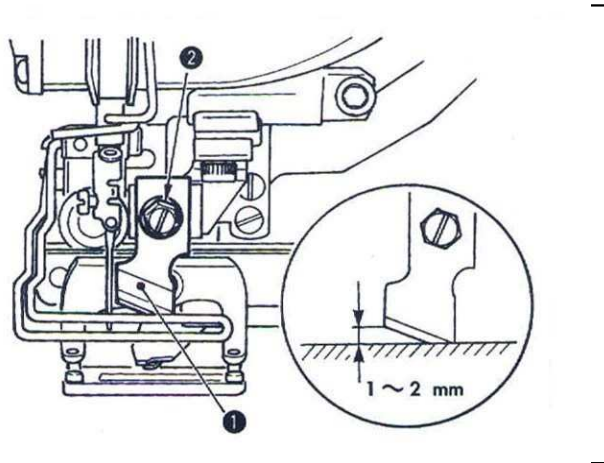

When replacing the knife with a new one, perform as follows.

- 1) Knife (1) can be easily removed together with the washer when removing knife retaining screw (2) .

- 2) Adjust so that the knife, when lowered the knife bar by hand, is spaced 1to 2 mm away from the top surface of the throat plate as illustrated in the sketch. Then, be sure to place the washer and tighten the knife retaining screw

inch mm/Inch mm CONVERSION TABLE mm CONVERSION TABLE

Knife size /inch	Indication of mm	Knife size /inch	Indication of mm
1/4	6.40	13/16	20.60
3/8	9.50	7/8	22.20
7/16	11.10	1	25.40
1/2	12.70	1 1/8	28.60
9/16	14.30	1 1/4	31.80
5/8	15.90	1 3/8	34.90
11/16	17.50	1 1/2	38.10
3/4	19.10		

V. MAINTENANCE

1. Adjusting the needle-to-hook relation

WARNING : To protect against possible personal injury due to abrupt start of the machine, be sure to start the following work after turning the power off and ascertaining that the motor is at rest.

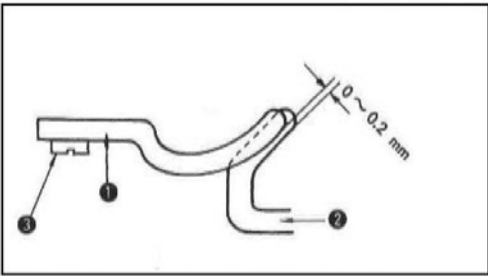
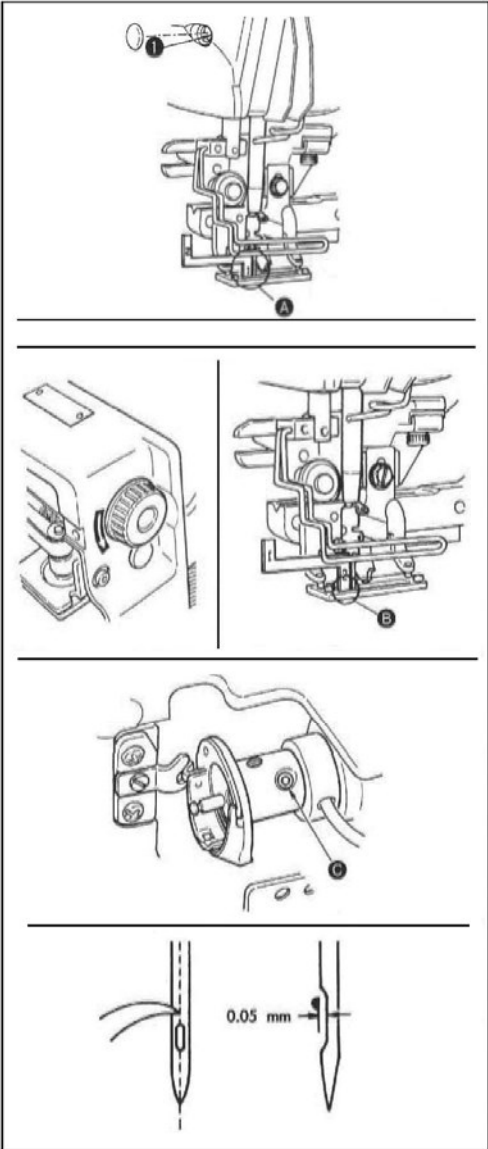

Adjust the needle-to-hook relation when the needle enters the center of the needle hole in the throat plate

(1) Needle bar height

Bring down the needle bar to the lowest point.
 Insert the part [1] of timing gauge into the gap between the bottom end of needle bar and throat plate, where the bottom end of the needle bar touches the top of the part [1] of the timing gauge. Loosen needle bar connection screw ❶, and adjust the height of the needle bar.

(2) Set the needle to hook relation in the following way:

Rotate the hand pulley in the correct direction until the needle starts to go up from its lowest point.
 Inset the part [2] of the timing gauge into the gap between the bottom end of the needle bar and the throat plate, where the bottom end of the needle bar touches the top of the part [2] of the timing gauge.
 Loosen setscrew of the hook sleeve, and align blade point of the sewing hook with the center of needle hole. Make adjustment so that a clearance of approx. 0.05mm is provided between the needle and the blade point of the hook.

(3) Adjusting the bobbin case positioning stopper
 Adjust with setscrew ❸ so that the contact of the top end of bobbin case positioning stopper ❶ and the end of inner hook ❷ is 0 to 0.2mm.

2. Adjusting the needle thread trimmer

CAUTION : To protect against possible personal injury due to abrupt start of the machine, be sure to start the following work after turning the power off and ascertaining that the motor is at rest.

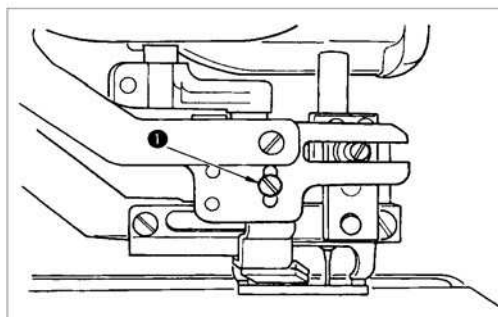
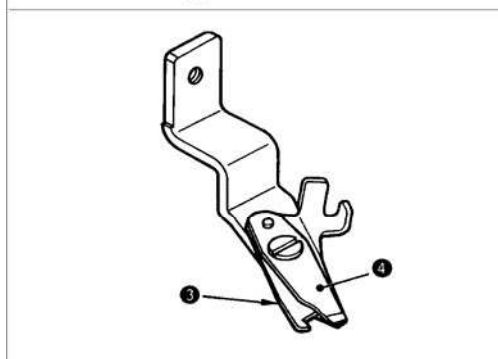
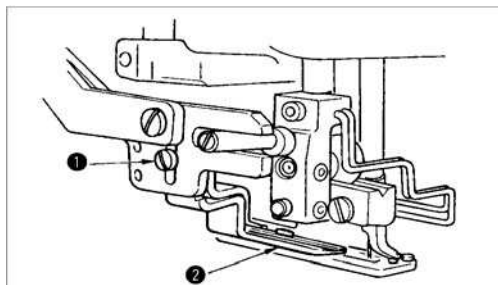

(1) Adjusting the thread grasping force of the needle thread trimmer

If the needle thread trimmer fails to provide consistent thread grasping force, the needle thread can slip off at the beginning of sewing.

1) If the thread grasping force of the needle thread trimmer has reduce, loosen setscrew ❶ and detach needle thread trimmer ❷.

2) Slightly bend the top end of thread presser spring ❸ so that it comes in contact with thread trimming blade of upper knife ❹ over the length with no clearance and so that the needle thread trimmer securely holds the thread regardless of the position of the thread trimming blade at which the thread is trimmed.

(2) Adjusting the height of the needle thread trimmer

To adjust the height of the needle thread trimmer, loosen setscrew ❶. Set the height of trimmer as low as possible, provided that it does not touch work clamp check, in order to minimize the length of remaining thread on the needle after trimming.

Note that the work clamp check tilts when sewing a multi-layered portion of the material, attach the needle thread trimmer to slightly raise the installing position of the trimmer.

3 . Adjusting the presser bar pressure

CAUTION : To protect against possible personal injury due to abrupt start of the machine, be sure to start the following work after turning the power off and ascertaining that the motor is at rest.

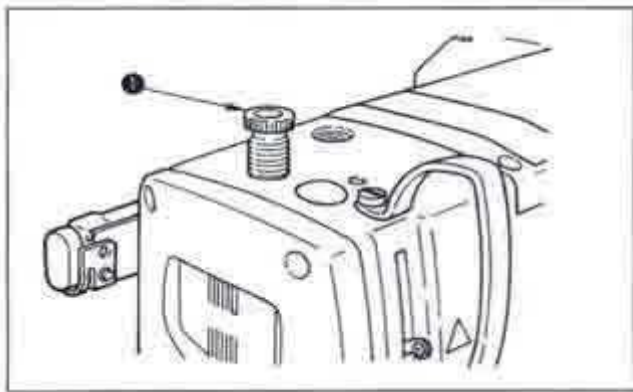

To adjust the pressure applied by the presser bar to fabric, turn presser spring regulator . When the pressure is not enough to prevent fabric from puckering, turn regulator clockwise. ❶

4. Adjusting of the bobbin presser unit

CAUTION : To protect against possible personal injury due to abrupt start of the machine, be sure to start the following work after turning the power off and ascertaining that the motor is at rest.

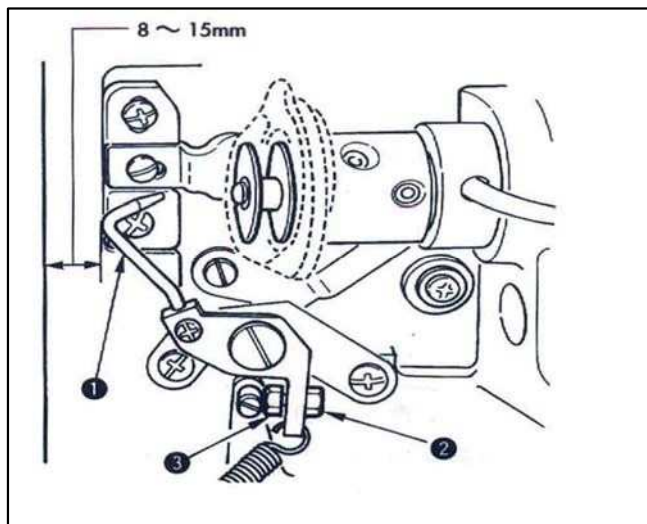

Loosen nut ② and adjust the position with stopper spring ③ so that the distance from the front end of machine bed to bobbin presser ① is 8 to 15mm when the sewing machine stops. Then tighten nut ②.

5. Thread tension

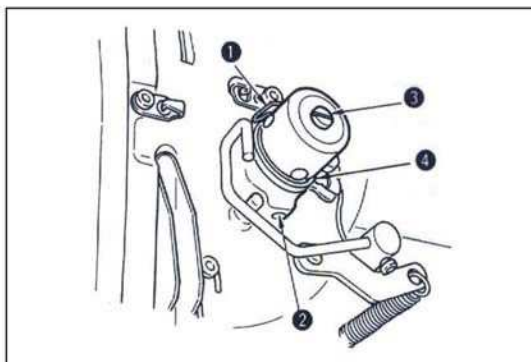

(1) Thread take-up spring (purl stitch)

- 1) The thread take-up amount of thread take-up spring ① is 8 to 10mm, and the appropriate pressure at the start is approximately 0.06 to 0.1N.
- 2) To change the stroke of the thread take-up spring, loosen screw ②, insert a thin screwdriver into the slot of thread tension post ③, and turn it.
- 3) To change the pressure of the thread take-up spring, insert a thin screwdriver into the slot of thread tension post ③ while screw ② is tightened, and turn it. Turning it clockwise will increase the pressure of the thread take-up spring.
Turning it counterclockwise will decrease the pressure.

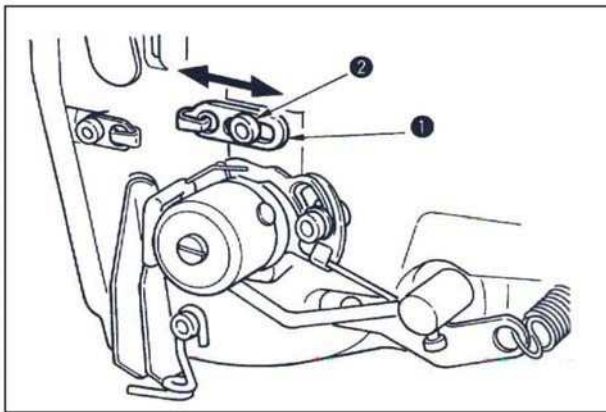

(2) Adjusting the thread take-up amount of the thread take-up lever

The thread take-up amount of the thread take-up lever should be adjusted in accordance with the thickness of the sewing products so as to obtain well-tightened stitches.

- a. For heavy-weight materials, loosen setscrew ② in thread guide ① and move the thread guide to the left the thread take-up amount of the thread take-up lever will be increased.
- b. For light-weight materials, move thread guide ① to the right. The thread take-up amount of the thread take-up lever will be reduced.

6. Cleaning the filter

WARNING : To protect against possible personal injury due to abrupt start of the machine, be sure to start the following work after turning the power off and ascertaining that the motor is at rest.

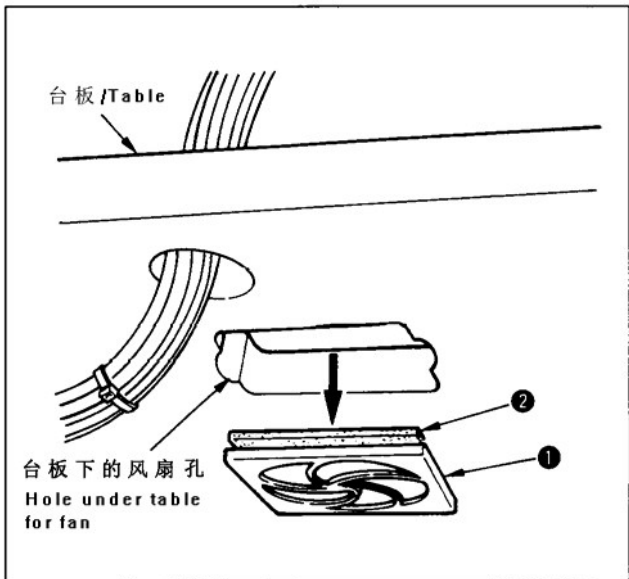

Clean filter ② of the fan located on the bottom surface of the machine table (bed base) once every week.

- 1) Pull the screen kit ① in the direction of the arrow to remove it.
- 2) Wash the filter ② under running water.
- 3) Reinstall the filter ② and the screen kit ①.

TROUBLES AND CORRECTIVE MEASURES

Trouble	Causes	Corrective measures	Page
1. Needle thread breakage	<ol style="list-style-type: none"> 1. Thread tension at parallel section is too high. 2. Pressure or stroke of thread take-up spring is too large. 3. There is a burr or scratch on the blade point of hook. 4. Hook timing is not proper. 5. There is a scratch on the thread path. 6. Attaching needle is wrong. 7. Needle is too thin. 8. Needle tip is damaged. 	<p>decrease the thread tension at parallel section.</p> <p>decrease the tension of thread take-up spring or decrease its stroke.</p> <p>Buff the blade point of hook. Or, replace the hook.</p> <p>Adjust again the hook timing with timing gauge.</p> <p>Polish the thread path with sand paper and buff it.</p> <p>Adjust again the direction, height, etc.</p> <p>Replace the needle with a thicker one.</p> <p>Replace the needle.</p>	<p>18</p> <p>15</p> <p>11</p> <p>11</p> <p>11</p>
2. Needle thread slips off.	<ol style="list-style-type: none"> 1. Needle thread trimmer opens too early. 2. Whip stitching is not formed at the start of sewing.(tension). 3. Threading needle thread is wrong. 4. Speed at the start of sewing is too fast. 	<p>Delay the opening timing of the needle thread trimmer.</p> <p>Decrease tension at the start of sewing.</p> <p>Thread properly again.</p> <p>Set the soft-start function.</p>	<p>12</p>
3. Wobbling at parallel section	<ol style="list-style-type: none"> 1. Thread tension at parallel section is too low. 2. Bobbin thread tension is too high. 3. Pre-tension is too low. 	<p>Increase the thread tension at parallel section.</p> <p>Decrease bobbin thread tension.</p> <p>increase pre-tension.</p>	
4. Wobbling at the start of sewing	<ol style="list-style-type: none"> 1. Thread tension at parallel section is too low. 2. Position of needle thread trimmer is too high. 3. Stroke of thread take-up spring is too large. 	<p>Increase the thread tension at parallel section.</p> <p>Lower the needle thread trimmer to such an extent that it does not come in contact with the presser.</p> <p>Decrease the stroke of thread take-up spring.</p>	<p>16</p> <p>18</p>

<p>5. Needle thread appears on the wrong side of material at bar-tacking section in dumpling condition.</p>	<ol style="list-style-type: none"> 1. Bar-tacking thread tension is too low. 2. Bobbin thread tension is too high. 3. Number of stitches of radial shape is too many. 4. Tension at the end of sewing is too many. 	<p>Increase the bar-tacking thread tension.</p> <p>Decrease the number of stitches Decrease the number of stitches. Increase tension at the end of sewing.</p>	
<p>6. Stitches float.</p>	<ol style="list-style-type: none"> 1. Bobbin thread tension is too low. 2. Bobbin thread comes off bobbin case. 	<p>Increase the bobbin thread tension. perform proper threading the bobbin case.</p> <p>take care that the winding amount of bobbin thread is not excessive.</p>	<p>13 12</p>
<p>7. Stitch skipping</p>	<ol style="list-style-type: none"> 1. Button hole is small in terms of the 	<p>Replace the presser with a smaller</p>	
	<ol style="list-style-type: none"> 2. size of presser. 3. Material flops because of light-weight. 4. Attaching needle is wrong. 5. Needle id bent. There is a burr or scratch on the blade point of hook. 	<p>one.</p> <p>Delay the hook-to-needle timing. (Lower the needle bar by 0.5mm) Adjust again the direction, height, etc.</p> <p>Replace the needle. Buff the blade top of hook. Or, replace the hook.</p>	<p>15 11 11</p>
<p>8. Thread frays.</p>	<ol style="list-style-type: none"> 1. Number of stitches of the stitching is too small. 2. Width of tie stitching is too wide. 	<p>Increase the number of stitches of tie stitching at the end of sewing. Narrow the width of tie stitching at the end of sewing.</p>	
<p>9. Length of needle thread remaining at the end of sewing is too long.</p>	<ol style="list-style-type: none"> 1. Width of tie stitching is too narrow. 2. Tension of tie stitching is too low. 	<p>Widen the width of tie stitching at the end of sewing.</p> <p>Increase tension at the end of sewing.</p>	
<p>10. Needle thread breaks at the start of sewing, or the wrong side of seam is dirty.</p>	<ol style="list-style-type: none"> 1. Tension at the start of sewing is too low. 	<p>Increase tension at the start of sewing.</p>	

CE DECLARATION OF CONFORMITY

Distributor:

Strima Sp. z o.o.

Swadzim, st. Poznańska 54

62-080 Tarnowo Podgórne, Polska

We declare, that the following product:

Electronic buttonhole machine

Texi O (ZJ5780S)

which this declaration relates, complies with the following directives:

Machine directive 2006/42/WE

Low voltage directive 2006/95/WE

Harmonized norm used: EN 60204-1